

NEXT

QUICK INSTALLATION GUIDE

NEXT MODULAR SYSTEM

Solo Fixture Installation





 VICON

NOTICES

- This camera operates at PoE (IEEE 802.3at minimum).
- Installation and service should be performed only by qualified and experienced technicians and comply with all local codes and rules to maintain your warranty.
- We are NOT liable for any damage arising either directly or indirectly from inappropriate installation which is not depicted within this documentation.
- To reduce the risk of fire or electric shock during installation, do not expose the product to rain or moisture.
- To remove fingerprints, dust, contaminants, etc., that could occur during installation, wipe the camera with a dry soft cloth. For tough stains, lightly apply a diluted neutral detergent and wipe with a dry soft cloth.
- Do not apply benzene or thinner to the camera, which may cause the surface to melt or lens to fog.
- Avoid aligning the lens with extremely bright objects (e.g., light fixtures) for long periods of time.
- Although this camera is waterproof and suitable for both indoor and outdoor usage, please do not immerse the camera into water.
- Avoid operating or storing the camera in the following locations:
 - Extremely humid, dusty, or hot/cold environments (recommended operating temperature: -40 to 131° F/-40°C to +55°C)
 - Close to sources of powerful radio or TV transmitters
 - Close to fluorescent lamps or objects with reflections
 - Under unstable or flickering light sources
- EN: This product should be supplied by Power-over-Ethernet (PoE).
The equipment should have on Power over Ethernet (PoE) standards as per IEEE802.3 (42.5-57VDC, 51W), Tma is 55 degree C minimum and altitude 5000m.
If you need further assistance, please contact the manufacturer or brand owner for more information.
- FR: Ce produit doit être alimenté par Power-over-Ethernet (PoE).
- L'équipement doit être conforme aux normes Power over Ethernet (PoE) selon IEEE802.3 (42,5-57 VDC, 51 W), la Tma doit être d'au moins 55 degrés C et l'altitude de 5 000 m.
- EN: The equipment powering the Camera should be connected to a socket-outlet with earthing connection.
- FR: L'équipement alimentant la caméra doit être connecté à une prise de courant avec mise à la terre.



WEEE (Waste Electrical and Electronic Equipment).
Correct disposal of this product (applicable in the European Union and other European countries with separate collection systems). This product should be disposed of, at the end of its useful life, as per applicable local laws, regulations, and procedures.

	<p>CAUTION RISK OF ELECTRIC SHOCK DO NOT OPEN</p>		<p>THIS SYMBOL INDICATES THAT DANGEROUS VOLTAGE CONSTITUTING A RISK OF ELECTRIC SHOCK IS PRESENT WITHIN THE UNIT.</p>
<p>CAUTION: TO REDUCE THE RISK OF ELECTRIC SHOCK, DO NOT REMOVE THE COVER. NO USER-SERVICEABLE PARTS INSIDE. REFER SERVICING TO QUALIFIED SERVICE PERSONNEL.</p>			<p>THIS SYMBOL INDICATES THAT IMPORTANT OPERATING AND MAINTENANCE INSTRUCTIONS ACCOMPANY THIS UNIT.</p>

FCC COMPLIANCE STATEMENT

Information to the user: This unit has been tested and found to comply with the limits for a Class A digital device pursuant to Part 15 of the FCC Rules. Operation is subject to the following two conditions: (1) this device may not cause harmful interference, and (2) this device must accept any interference received, including interference that may cause undesired operation. These limits are designed to provide reasonable protection against harmful interference in a residential installation. This unit generates, uses, and can radiate radio frequency energy and, if not installed and used in accordance with the manual, may cause harmful interference to radio communications. However, there is no guarantee that interference will not occur in a particular installation.

If this unit does cause harmful interference to radio or television reception, which can be determined by turning the unit off and on, the user is encouraged to try to correct the interference by one or more of the following measures:

- Reorient or relocate the receiving antenna.
- Increase the separation between the unit and receiver.
- Connect the unit to an outlet on a circuit different from that to which the receiver is connected.
- Consult the dealer or an experienced radio/TV technician for help.

CAUTION Changes or modifications not expressly approved by the party responsible for compliance could void the user's authority to operate the unit.

ATTENTION: Les changements ou modifications non expressément approuvés par la partie responsable de la conformité peuvent annuler le droit de l'utilisateur à utiliser l'appareil.

CE STATEMENT

Operation is subject to the following two conditions: (1) this device may not cause harmful interference, and (2) this device must accept any interference received, including interference that may cause undesired operation. The manufacturer declares that the unit supplied with this guide is compliant with the essential protection requirements of EMC directive and General Product Safety Directive GPSD conforming to requirements of standards EN55032, EN55035, EN61000-3-2, EN61000-3-3, IEC 61000-4-2, IEC 61000-4-3, IEC 61000-4-4, IEC 61000-4-5, IEC 61000-4-6, IEC 61000-4-8, and IEC 61000-4-11 for emission and immunity and UKCA.

This product is IP67 rated for outdoor environments and IK10 rated for impact protection. The camera product also meets regulations required to be NDAA, GSA schedule and TAA approved.

IN THIS GUIDE

SURFACE MOUNT INSTALLATION	5
Package(s) Contents	5
Installation	6
Determine the Centerline	6
Reset Button	7
Mount the Base to the Surface	8
Connect the Cables	10
Assemble the Components	11
Install the Camera Sensor	13
CAMERA CONFIGURATION	16
On-Prem Systems	16
Anavio Cloud-Based System	17
Network Requirements and IP Configuration	18
Switching Between Anavio and On-Prem Systems	18

SURFACE MOUNT INSTALLATION

Package(s) Contents

Solo Fixture Kit

VNX-FX-SOBK-0

- Base
- Network Hub
- Solo Fixture
- Mounting Screw Kit
- IP67 RJ-45 Connector Shell
- T8 Security Torx Wrench

Sensor Module

VNX-SN-VRS1-0

- NEXT Camera Sensor

Vicon Edge Recording Card (optional)

VNX-EL-SD5G-0/VNX-EL-SD1T-0

- 512GB card
- 1TB card

Required for onboard recording for both On-Prem and Anavio cloud-based VMS platforms. Only Vicon Edge Recording cards are accepted.

When unpacking, check to see if there is any visible damage to the appearance of the camera and its accessories. Remove the protective materials from the camera after every item is properly checked.

CAUTION: To minimize the possibility of moisture being trapped inside the Camera Sensor, keep the sensor module in its factory-sealed bag with the desiccant bag intact until it is ready to be installed.

NOTE: The NEXT Base can mount directly to a single gang box. When a 4-square, double gang or octagon box is being used, the Electrical Box Adapter Plate is required. 

Installation

Determine the Centerline

The centerline refers to the home position of the camera lens, and before you begin your installation, you'll need to determine where that home position will be. Once installed, the "C" (for centerline) on the Base will align with the Vicon logo on the Solo Fixture and the lens home position (default position out-of-the-box). So, before you mount the Base to its surface, make sure the "C" on the Base reflects your home position.

For **ceiling surface mount applications**, the centerline is synonymous with the front of the camera. For **wall surface mount applications**, the centerline will be facing down.

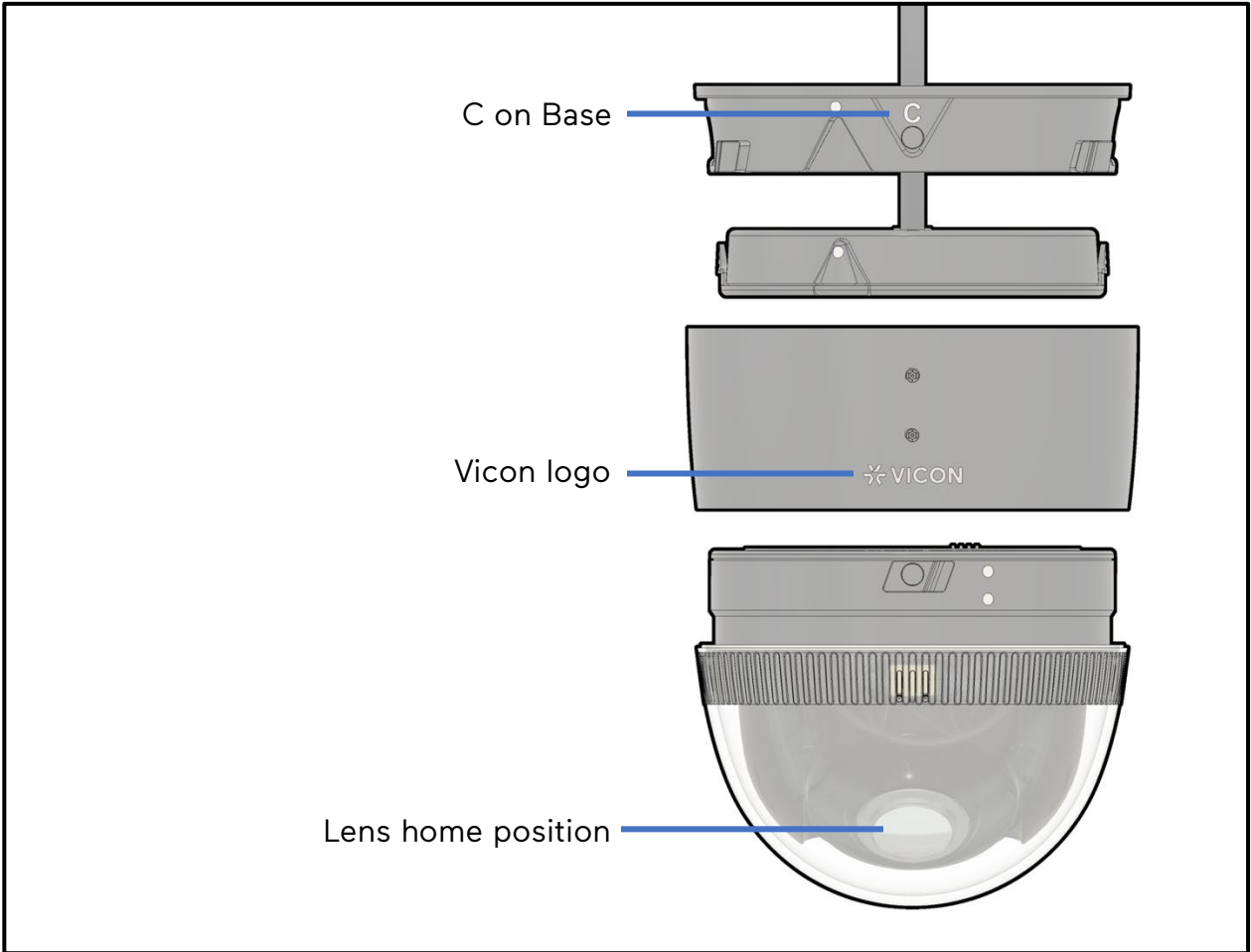

Reset Button

There is a Reset button on the Hub. Hold the button for 3 seconds to reboot the camera; all settings will be retained. Hold the button for 10 seconds to return the camera to factory default settings.

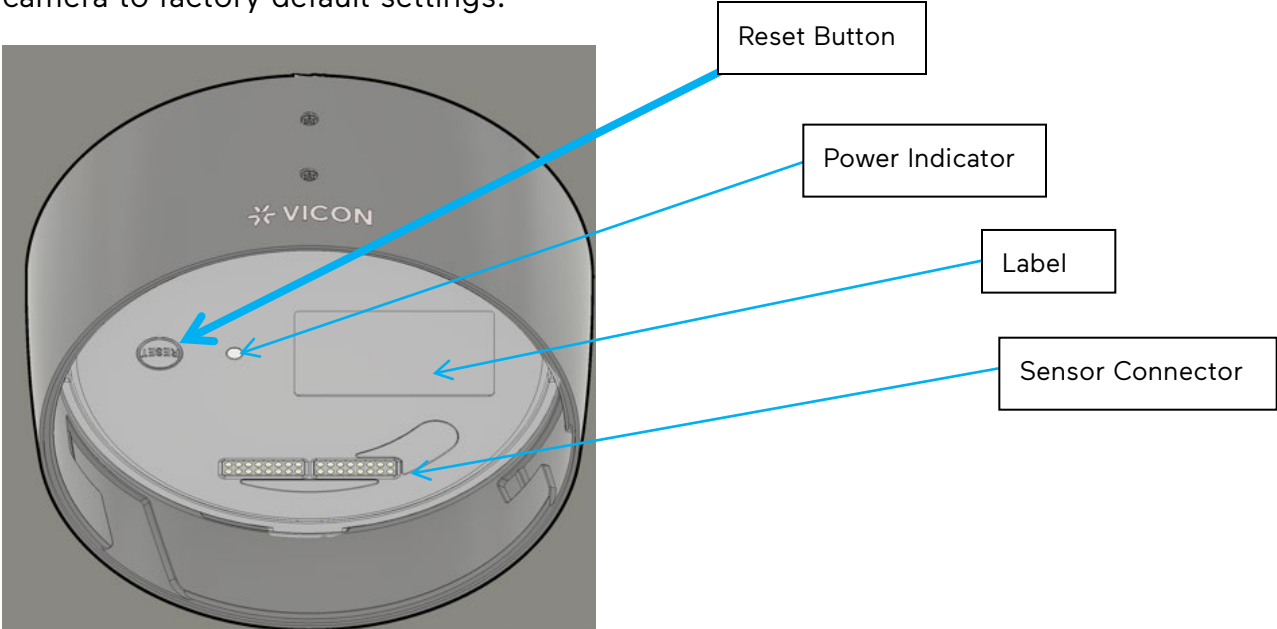

Mount the Base to the Surface

1. Drill a cable access hole in the surface where the camera will be mounted and expose the ethernet cable and alarm wiring.

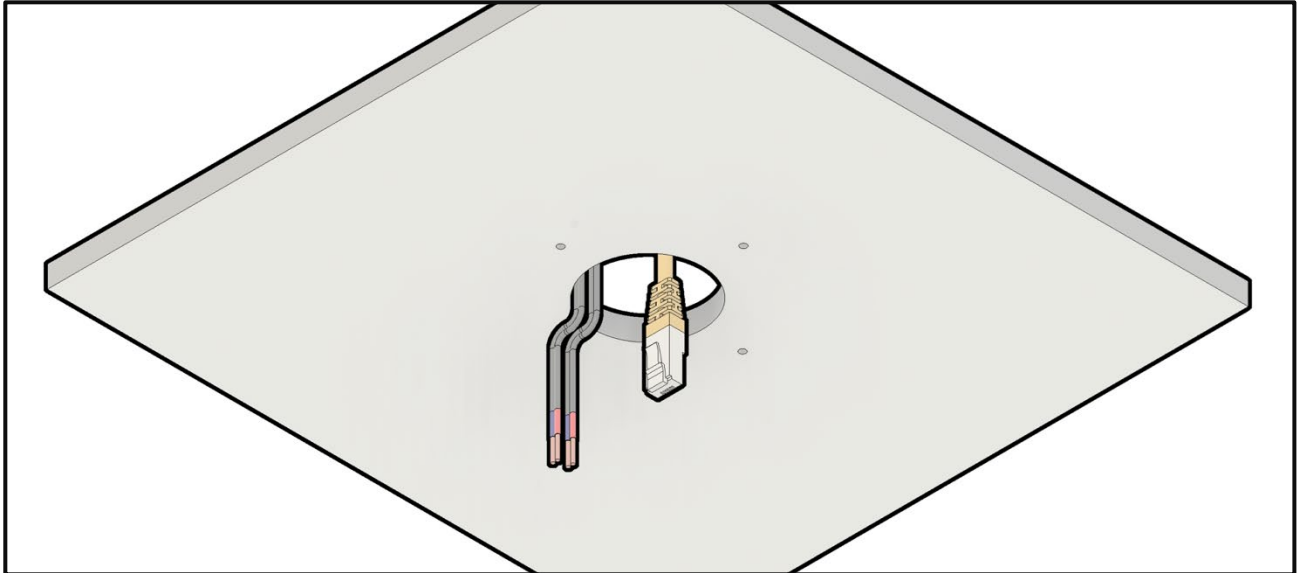

2. Once you've determined your centerline, use the Base to mark holes for the four mounting screws.

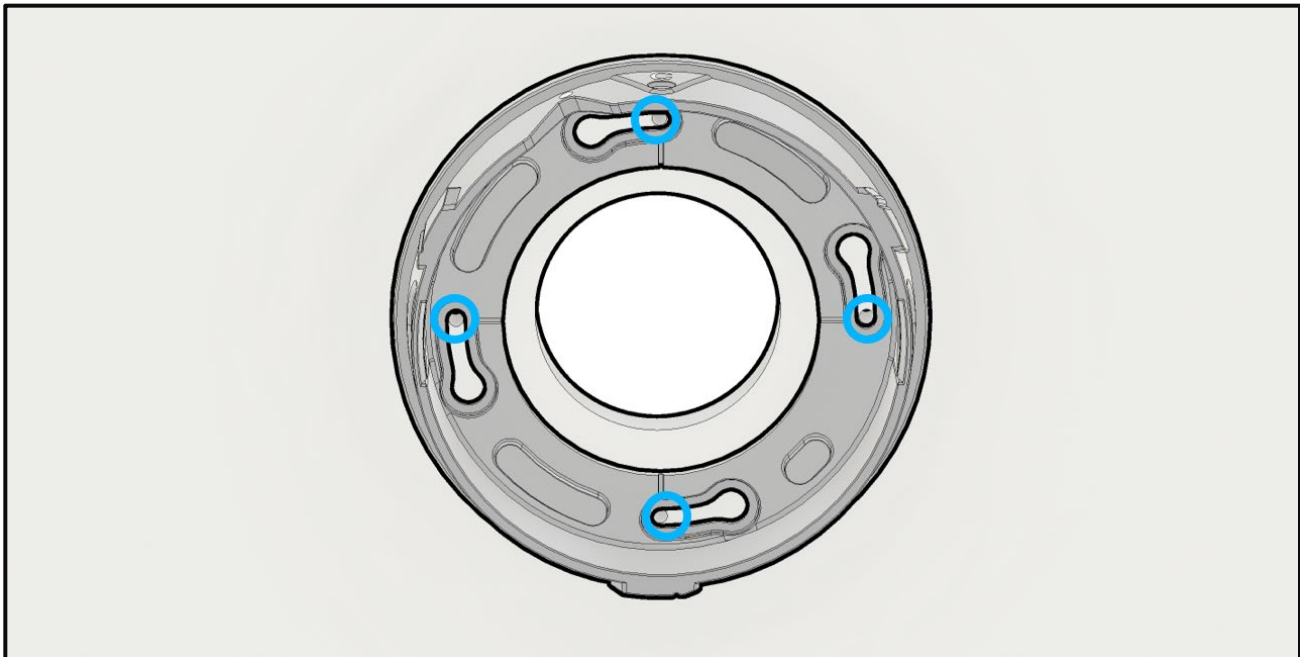

Reminder: The "C" on the Base indicates the centerline, which is the lens home position. For ceiling mount applications, C = front of the camera; for wall mount applications, the C should be facing the floor.

3. Set the Base aside; drill holes and install plastic anchors in those holes (Ø6.35 mm).

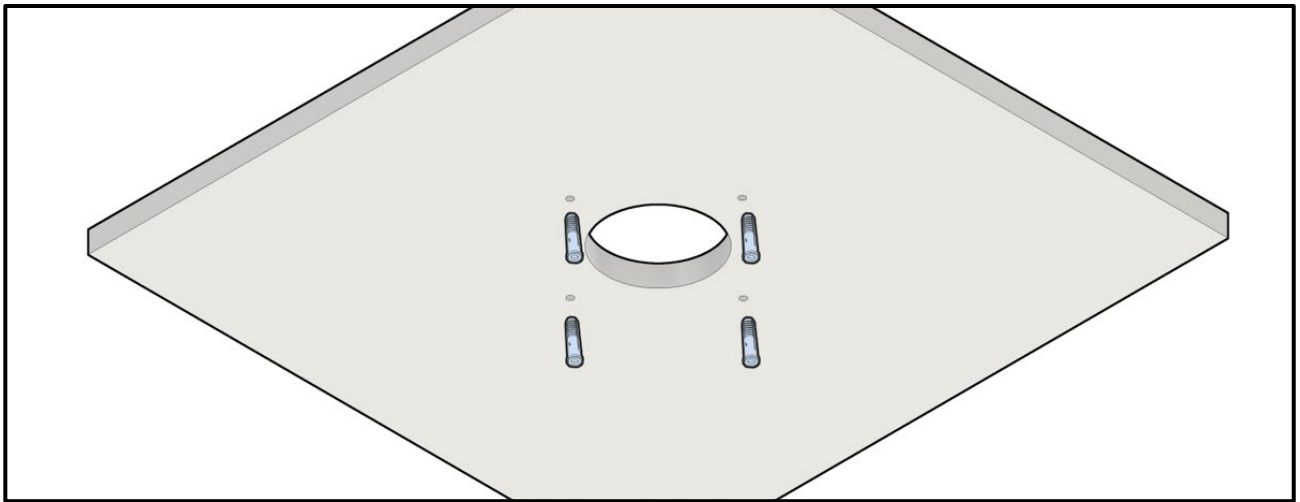

4. Reposition the Base and attach it to the surface using supplied screws.

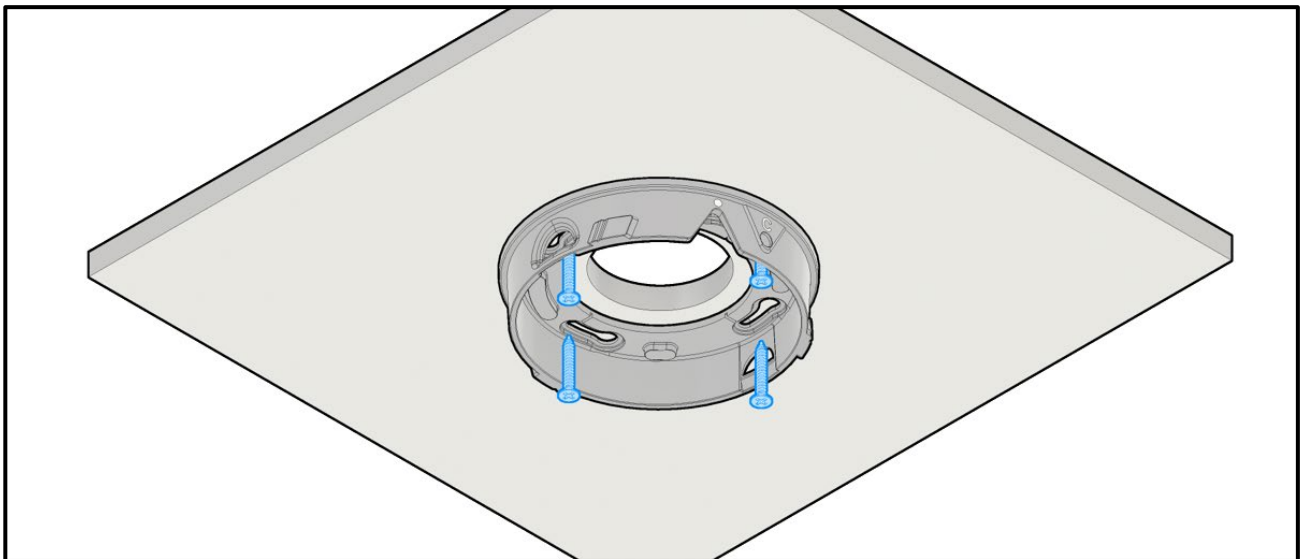

Connect the Cables

1. Connect the ethernet cable to the RJ-45 on the Network Hub.

NOTE: For outdoor installations, assemble the IP67 Connector Shell over the network cable, then connect and seal.

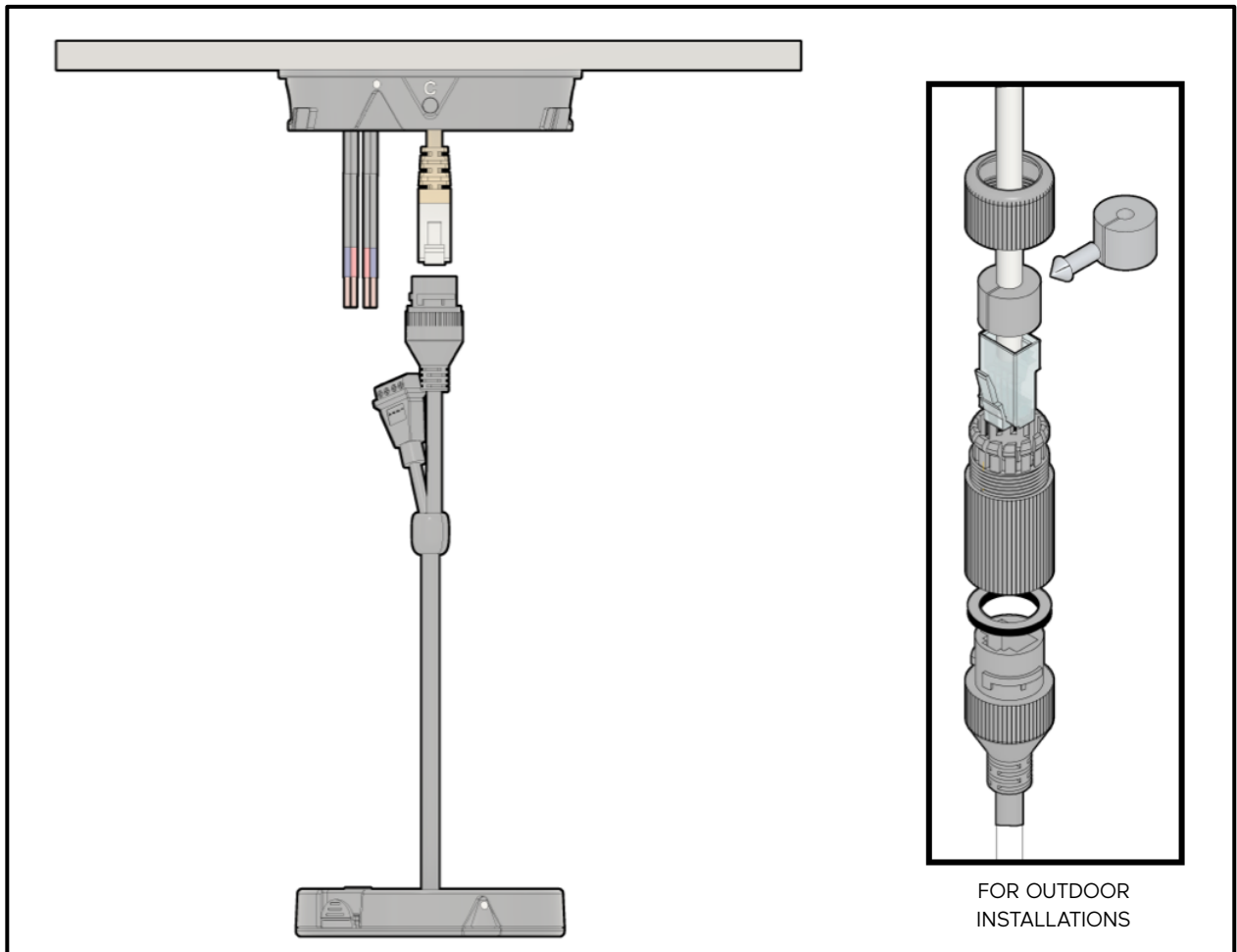

2. Connect the Alarm I/O as required.

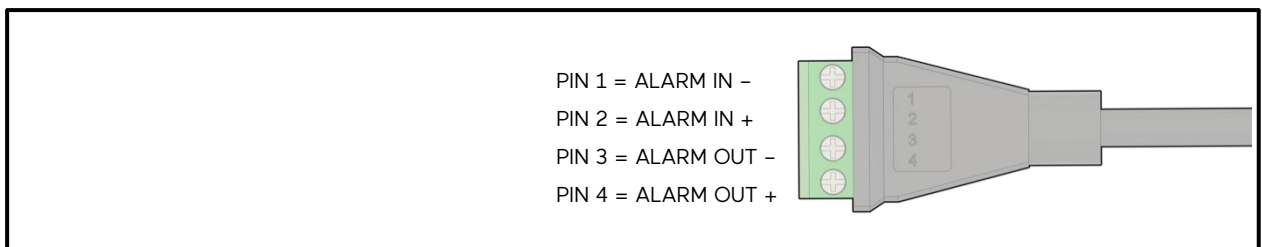

Assemble the Components

1. Align the single dot indicator on the Network Hub with the dot on the Base and firmly snap the Network Hub into place.

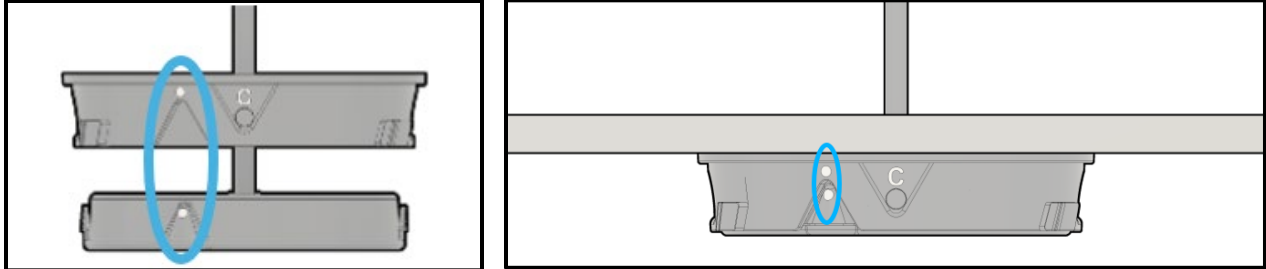

Minimum 802.3at PoE is required to power the camera.

2. Observe the LED on the Network Hub to determine if there might be a potential power issue. The LED will be solid red when power is detected.
3. Align the two lock screws on the Solo Fixture with the double dot indicators on the installed Network Hub.

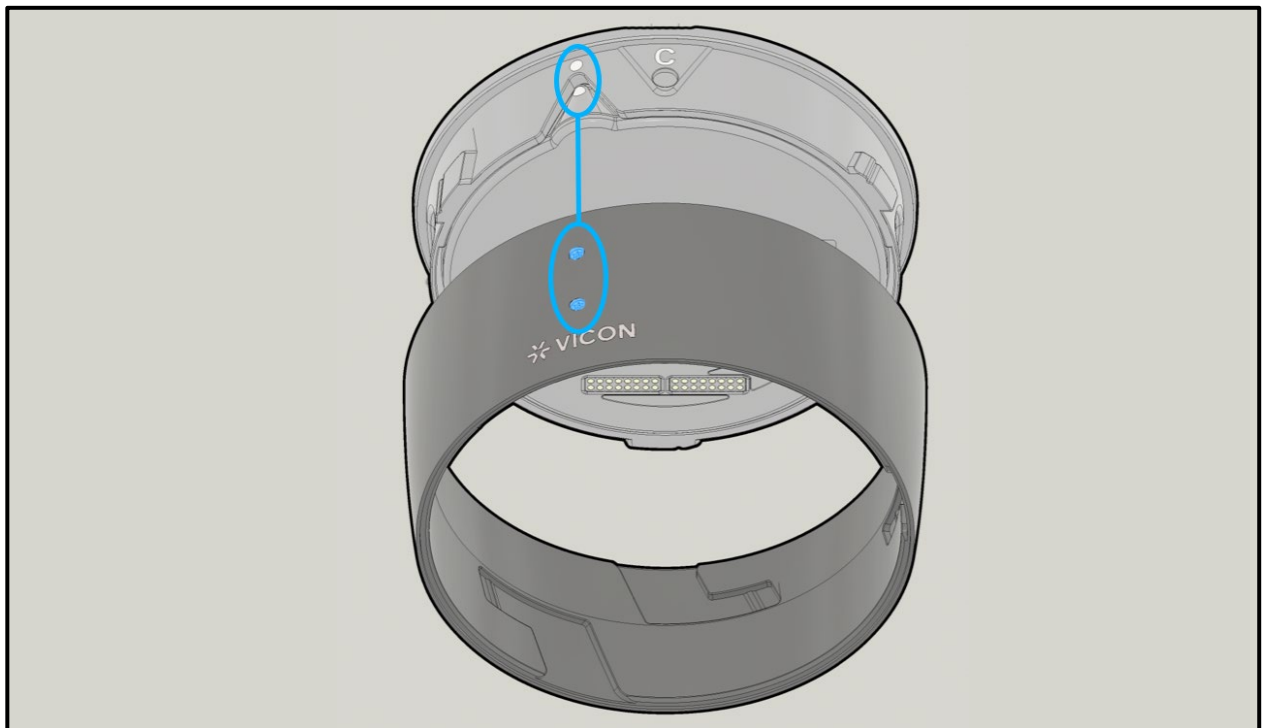

4. Twist the Solo Fixture to the right to lock it into place. The Vicon logo on the Solo Fixture is now aligned with the Base's centerline ("C").

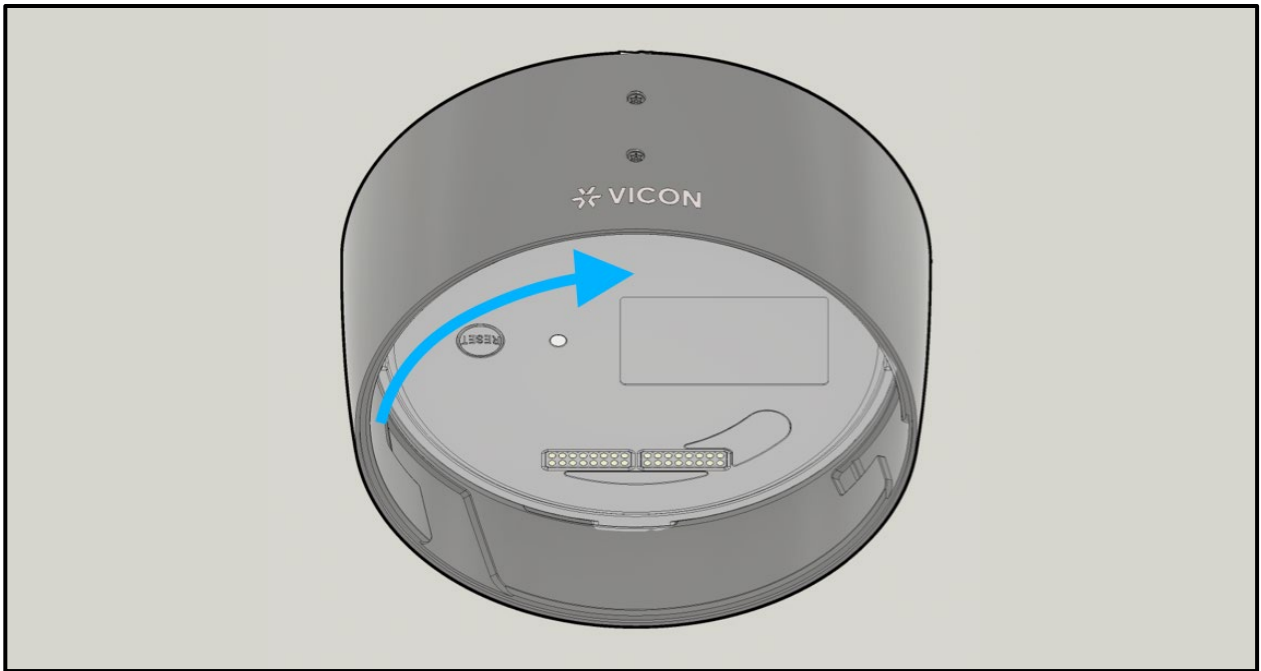

Install the Camera Sensor

1. Just prior to installation, remove the Camera Sensor from the factory-sealed bag.
2. If using edge recording for On-Prem or Anavio solutions, install the Vicon Edge Recording Card (VNX-EL-SD5G-0 or VNX-EL-SD1T-0).

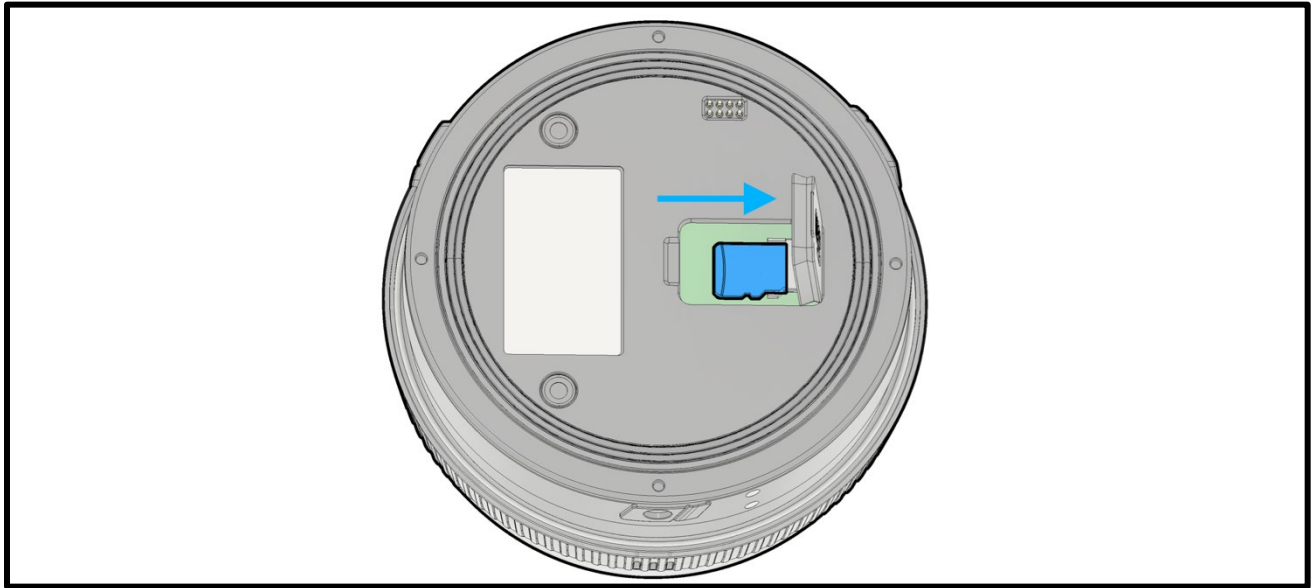

NOTE: Only the Vicon Edge Recording cards (VNX-EL-SD5G-0/VNX-EL-SD1T-0) are accepted.

3. Align the double dot indicators on the Camera Sensor with the two lock screws on the Solo Fixture, then twist it to the right to lock it into place.

NOTE: The NEXT cameras are built with a special membrane to allow internal moisture to vent, ensuring the IP67 rating. However, in certain environments, some moisture vapor may pass through. Upon powering up the camera, there may be some temporary condensation inside the bubble. This is normal and will typically clear on its own within 2-4 hours but may take longer based on the environment.

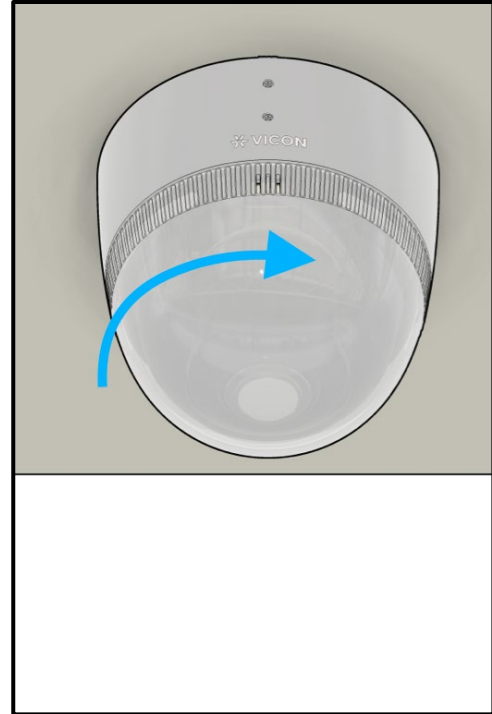
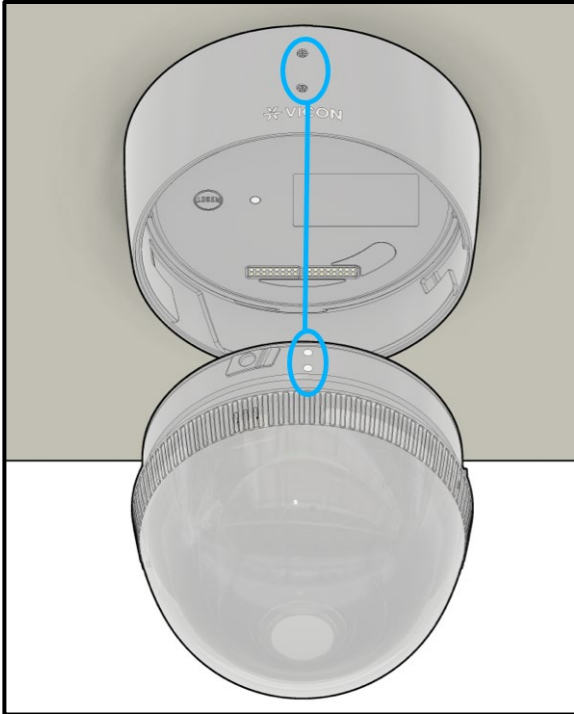

Upon successful installation, the LED lightbars on the Camera Sensor will sequence as below.

- LED will flash yellow for about 10 seconds - power is detected.
- LED will flash yellow/red for about 5 seconds - Hub to sensor communication is detected.
- LED will be solid white for 3 seconds - power is being tested.
- LED will flash red - insufficient power.
- LED will flash purple/red for 15 seconds - a non-Vicon uSD card is detected.
- LED will flash purple/blue for 15 seconds - Vicon uSD card is detected.
- LED will flash green for 15 seconds when installation is successful.

NOTE: If insufficient power is detected, the system will reboot, and the LED lightbars will flash red. You will need to check and replace your power source to 802.3at (for a solo or duo) or 802.3bt (for a solo, duo, trio or quad).

NOTE: If using Anavio, an Edge Recording card is required. If you do not see a purple LED signal, an Edge Recording card is not installed, and you will not have any recorded video

- Turn the security screw approximately 2 turns maximum until it contacts the Base and Camera Sensor. This prevents the camera from being removed. No torque is required (refer to warning label). For added security, use the T8 Security Torx wrench to gently tighten the two lock screws.

NOTE: Do not overtighten; overtightening can strip the threads.



- Remove the WARNING label from the Fixture.

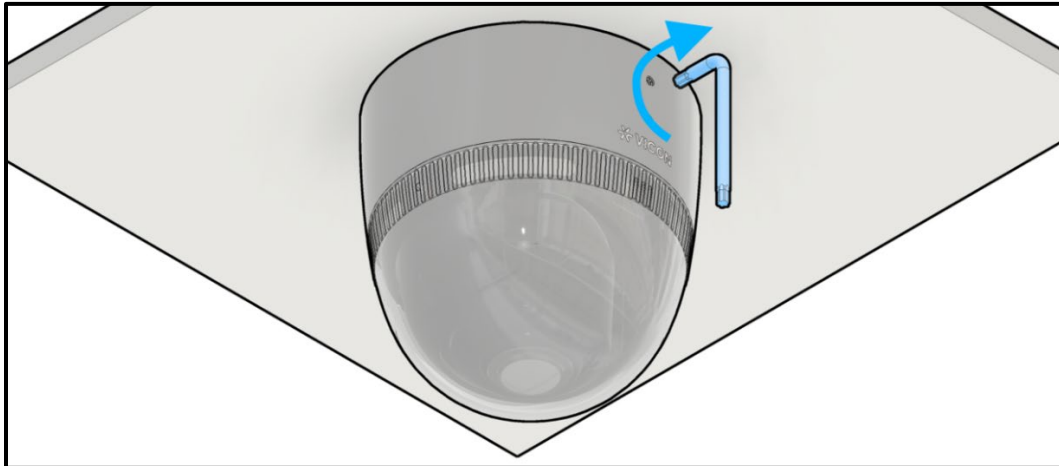

Congratulations on a successful installation!

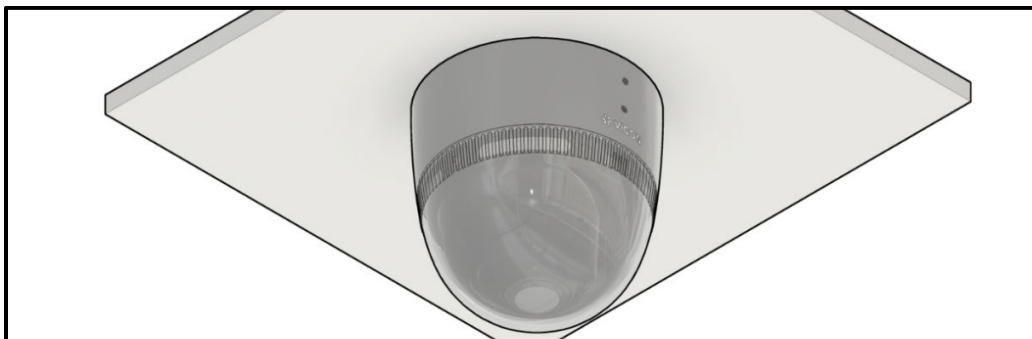

CAMERA CONFIGURATION

On-Prem Systems

For On-Prem installations (Valerus and 3rd party VMS platforms), the camera can be accessed using Vicon's PRONTO Device Manager and Discovery Tool, which can be found on Vicon's [website](#).

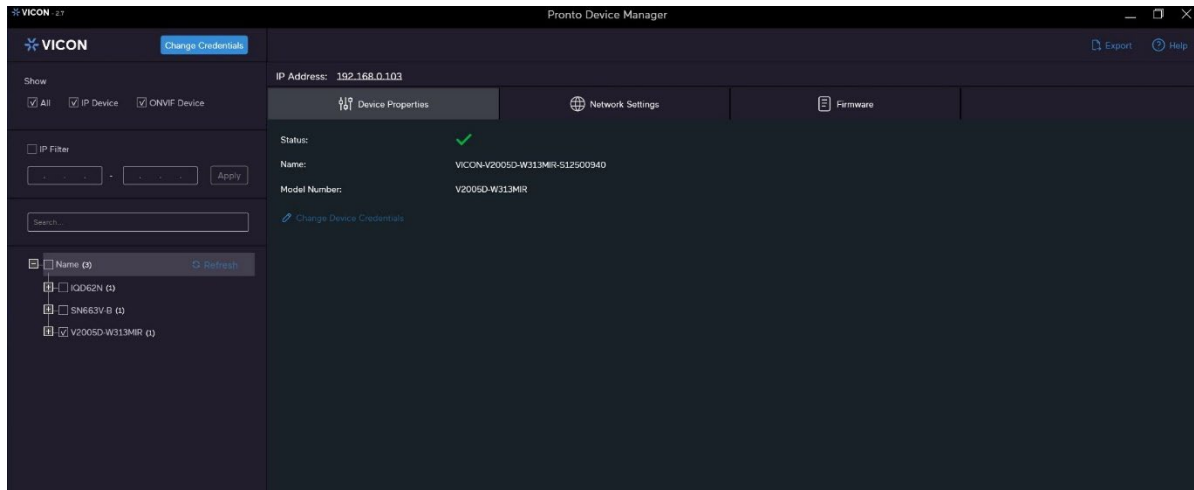

- When you start up the PRONTO Device Manager, the tool's auto-discovery function generates a list of the discovered cameras on the network in a resource list.
- There are a variety of filtering options, including filter by All Devices/IP Device/ONVIF Device, IP range or text.
- There are tabs for Device Properties, Network Settings and Firmware.

The complete PRONTO [User Manual](#) can be found on Vicon's website.

Anavio Cloud-Based System

You must have an Anavio account to use the cloud-based VMS system.

NOTE: Vicon Edge Recording card required. The NEXT camera must be set at default prior to connecting to Anavio.

1. Once your Anavio account is setup, log in and go to the **Devices** section on the left pane to add the new camera, then click **Add Device**.

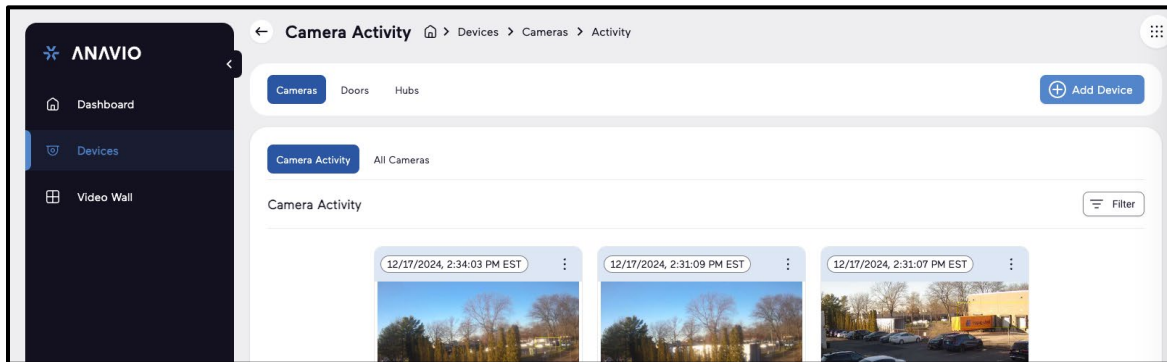

2. Enter the Hub's serial number and click **Add**, then click **Add Device**.

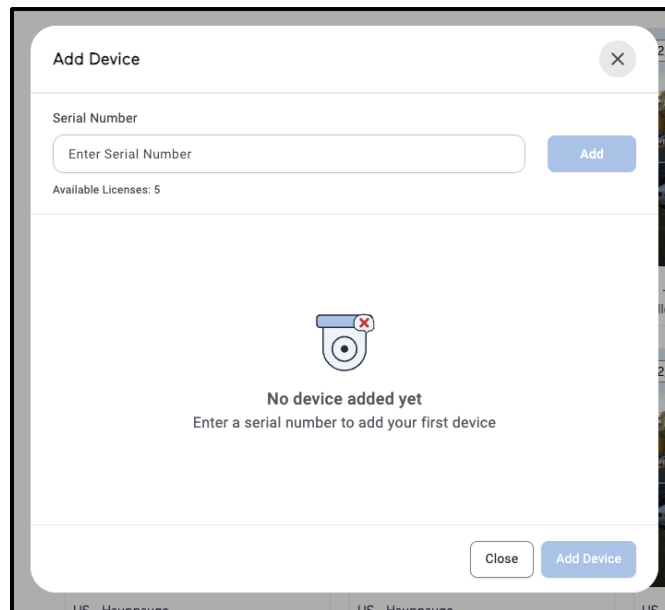

NOTE: After the Hub is added, up to four camera sensors can be connected to a Hub. The specific camera serial number does not have to be entered into Anavio.

Network Requirements and IP Configuration

Devices are set to get an automatic IP address via DHCP. If it is necessary to connect via manual IP, first plug the device into a DHCP enabled network to get it connected to the Anavio cloud software. From the settings, assign the IP manually. Note that if this IP has a different subnet segment as the one that was assigned through DHCP, the device won't be able to be accessed until it is in the new network.

To connect directly to the Anavio cloud software, an active internet connection is required. If the camera is in a managed network, firewalls, or any other security method that might restrict internet ports; make sure to contact the network administrator to open the following ports and domains:

- Device Communications Port number: 8883
- Software Communications Port number: 443
- STUN Protocol Port number: 3478
- NTP Port number: 123

For additional information, visit help.anavio.ai for instructions.

Switching Between Anavio and On-Prem Systems

To reuse the camera in Anavio or ONVIF mode, a full factory reset is required.

NOTE: When switching from ONVIF to Anavio, the Vicon Edge Storage Card is required. Do not configure credentials on the camera's webpage and ensure the device is connected to the Internet before adding it to Anavio.



Vicon Industries Inc. does not warrant that the functions contained in this equipment will meet your requirements or that the operation will be entirely error free or perform precisely as described in the documentation. This system has not been designed to be used in life-critical situations and must not be used for this purpose.

Document Number: 8009-8344-10-07 Rev: 10/25
Product specifications subject to change without notice
Copyright © 2025 Vicon Industries Inc. All rights reserved.

24-Hour Technical Support:
800-34-VICON (800-348-4266)
UK: 44/(0) 1489-566300
Toll Free: 800-645-9116

T: 631-952-2288
F: 631-951-2288